

TSC-1

30 » 2500kg Capacity

TENSION LOAD CELL

APPLICATIONS

Silos - Tanks.
Hopper weighing - Crane Scales.

FEATURES

Tension load cell.
3000 divisions OIML R60 Class C.
Hermetically sealed by laser welding.
Fully stainless steel construction.
Protected against humidity IP68 (EN60529).

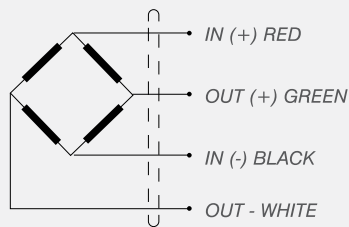

C.N. (kg)	30	50	100	150	300	500	750	1000	1500	2000	2500
A	12.5	12.5	12.5	12.5	20	20	25	25	25	25	25
B	M6	M6	M8	M8	M12	M12	M16	M16	M16	M16	M16



SPECIFICATIONS

Nominal capacities (Ln)	30-50-100-150-300-500-750-1000-1500-2000-2500 kg
Accuracy class	3000 n. OIML
Minimum dead load	0 %Ln
Service load	150 %Ln
Safe load limit	200 %Ln
Maximum combined error	<±0.017 %Sn (1) (3)
Repeatability error	<±0.015 %Sn
Temperature effect:	<±0.01 %Sn/5°C
On zero on sensitivity	<±0.006 %Sn/5°C
Creep error (30 minutes)	<±0.016 %Sn
Temperature compensation	-10 - +40 °C
Temperature limits	-20 - +50 °C
Nominal sensitivity (Sn)	2±0.1% mV/V (2)
Nominal input voltage	10 V
Maximum input voltage	15 V
Input impedance	386Ω±2%
Output impedance	350±3Ω
No load output	< ±2 %Sn
Insulation resistance	> 5000 MΩ
Maximum deflection	0.2-0.4 mm
Cable length	5 m

Dimensions (mm)

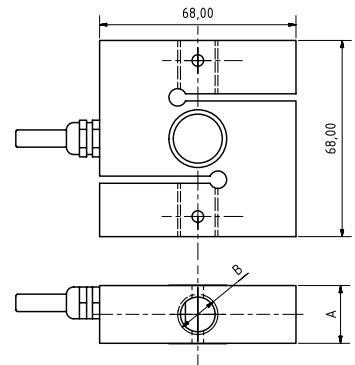

Reference	Nominal capacities - Ln (kg)	Accuracy class n. OIML	y = emax / vmin	#Code
TSC-1/30	30	C3	7500	710247
TSC-1/50	50	C3	7500	710248
TSC-1/100	100	C3	7500	710249
TSC-1/150	150	C3	7500	710250
TSC-1/300	300	C3	7500	710251
TSC-1/500	500	C3	7500	710252
TSC-1/750	750	C3	7500	710253
TSC-1/1000	1000	C3	7500	710254
TSC-1/1500	1500	C3	7500	710255
TSC-1/2000	2000	C3	7500	710256
TSC-1/2500	2500	C3	7500	710257

Ref.	Description	#Code
RTSC	Check dimensions on page Rod end accessories	PAGE 58